

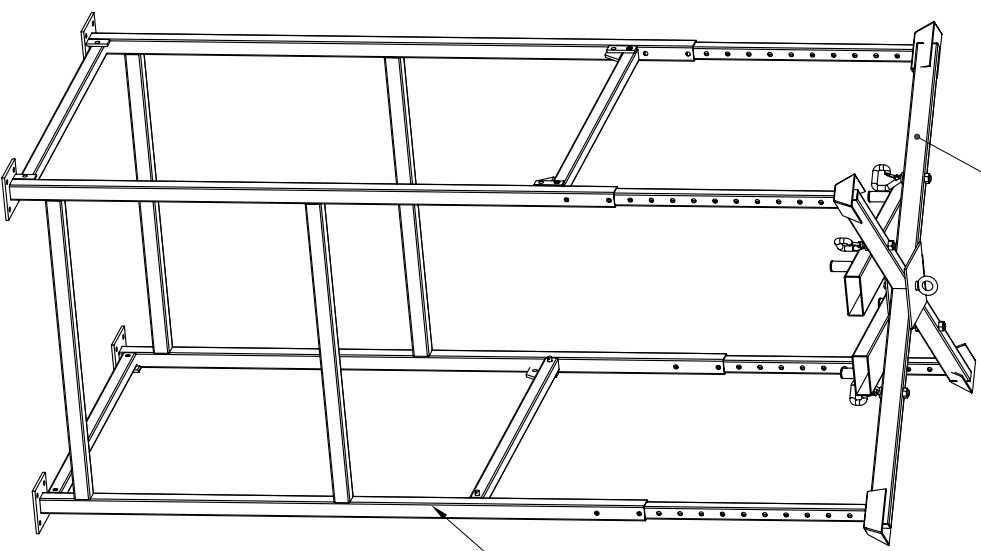

[www.haywardgordon.com](http://www.haywardgordon.com)

**DuraChem™ Bulk Bag Handling Systems**

ITEM NO.	PART NUMBER	DESCRIPTION	QTY.
1	201935	STAND BULK BAG 119-169 HEIGHT 60X60 44W	1
2	201939	NEW CROSS SUPERSACK 44W 94 60X60 FRAME	1

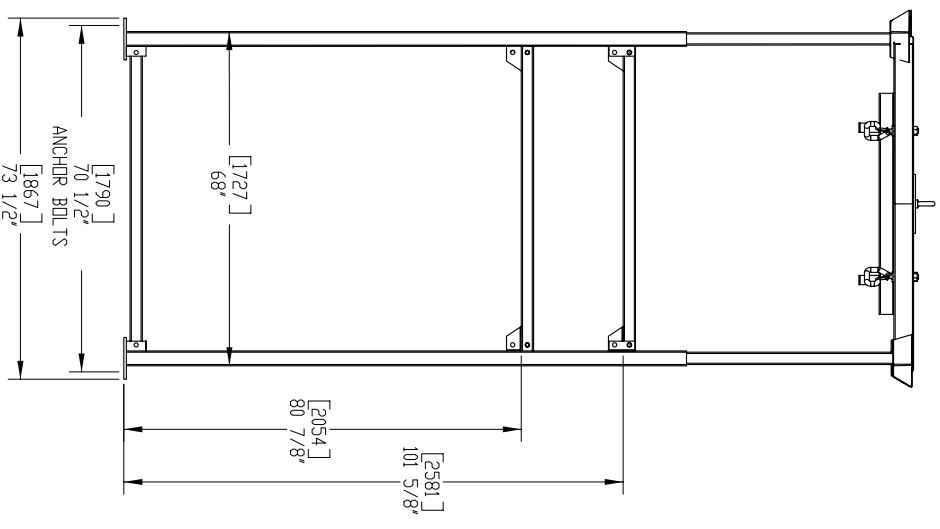
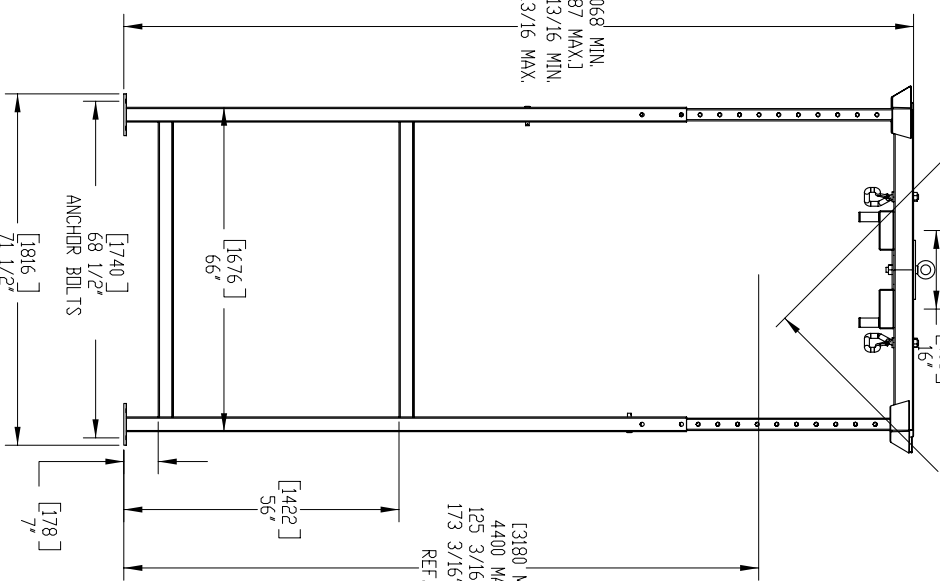
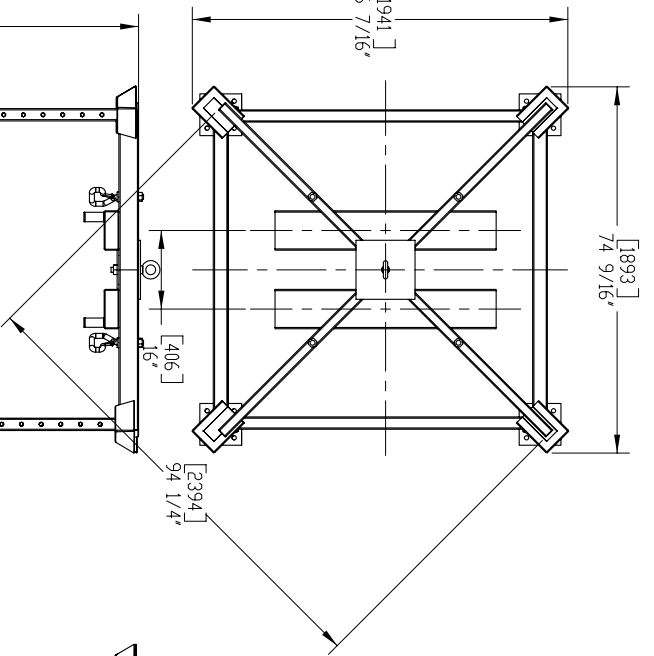
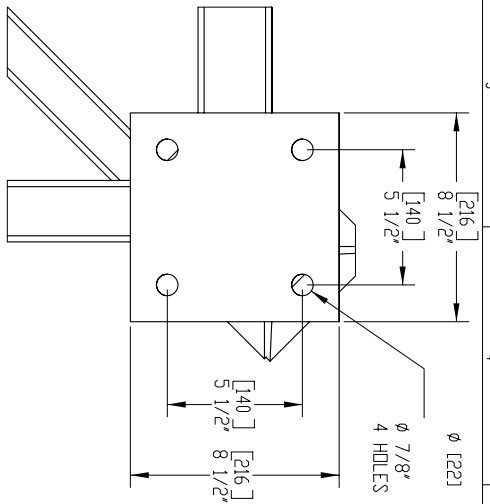

NOTE:  
HEIGHT ADJUSTABLE IN 4" (100MM) INCREMENTS.



**HAYWARD GORDON LTD.**  
TORONTO, MONTREAL, CALGARY, VANCOUVER  
PIPE MIXERS, STRAINERS, FILTERS  
& CUSTOM ENGINEERED SYSTEMS

THIS DRAWING IS THE SOLE PROPERTY OF HAYWARD GORDON LTD. AND MAY NOT BE USED OR COPIED EXCEPT AS EXPRESSLY AUTHORIZED BY IT. THIS DRAWING IS SUBJECT TO RECALL.

TITLE: STANDARD BULK BAG STAND, CROSS SUPERSACK 44W 94 FOR 60X60 FRAME

DRAWN: SK	DATE: 13/14/2006	SHEET 1 OF 1	SIZE C
SCALE: N/A	DWG. NO.: Sales Drawing	REV. 0	