

Draft Tube Mixers

The use of a mixing impeller located in a draft tube has been employed in the industrial and municipal industries for well over 20 years.

Although there is a larger initial capital cost for the draft tube assembly, the mixer power requirements, shaft length (and therefore diameter) and gear reducer size are all reduced resulting in a lower capital cost for the mixer and lower operating costs.

The draft tube not only directs the flow pattern more effectively than in an open mixing system, resulting in more efficient mixing, but also allows taller, narrower tanks to be used which results in the saving of plant real estate.

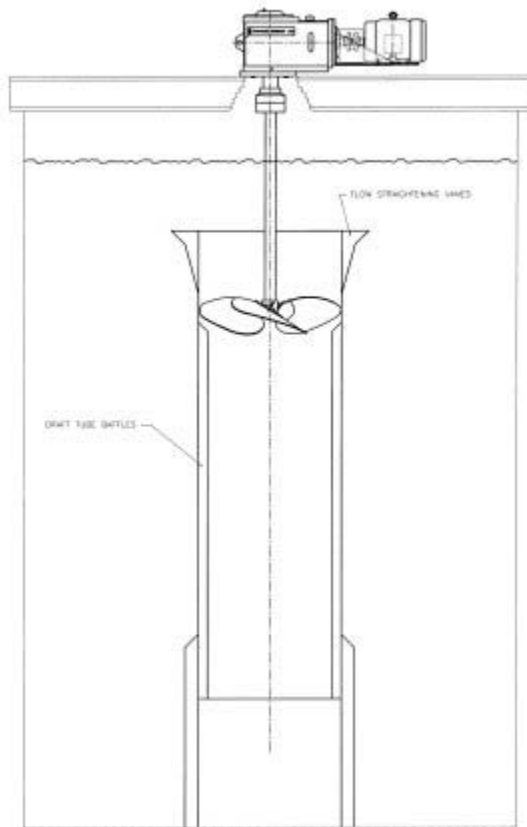

Typical down pumping arrangement in a tall form tank

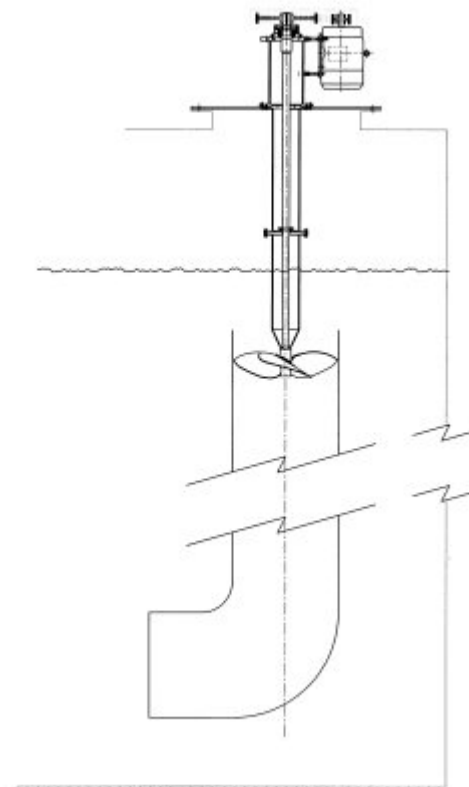

Sludge Circulator

Down pumping hydrofoil impellers are normally used with draft tubes and in these cases it is beneficial to flare the top of the tube for more efficient fluid flow into the tube.

In addition, flow-straightening vanes in this flared section are normally employed for more effective pumping. The top of the draft tube is normally located between 0.5 and 0.8 times the tube diameter below the fluid level with the impeller located at the end of the flared section.

The two major criteria involved in selecting the correct impeller are pumping capacity and head requirement (due to friction losses and restrictions). As the head requirement increases, wider blades are used to minimize the fluid flow back through the impeller (slip).

As the head requirement grows further, more blades per impeller are used and finally a second impeller can be added to the shaft - in some cases, we have supplied dual impellers with 5 blades per impeller to meet the head requirements.

Sample Draft Tube Mixer Applications:

Customer	Application
GL&V / Dorr Oliver (OEM)	Up-pumping Mixers for Flocculation
City of Berryville	Sludge Circulation
CAN-ENG (OEM)	Engine Casting Cleaning
IMC Kalium	Suspension & Circulation of Potash Slurry
Placer Dome	Gold Leaching
Environmental Equipment (OEM)	Up-pumping Mixers for Flocculation
City of Forest	Sludge Circulation
DuPont	Nylon Crystallization
City of Ozark	Digester Mixing
First Chemical	Nitrobenzene Washer Separator
American Cyanamid	Xylene & Alkyl Nitration